

Mitutoyo

Mitutoyo Quality

Shop-floor Type CNC Coordinate Measuring Machine MiSTAR Series

Coordinate Measuring Machines

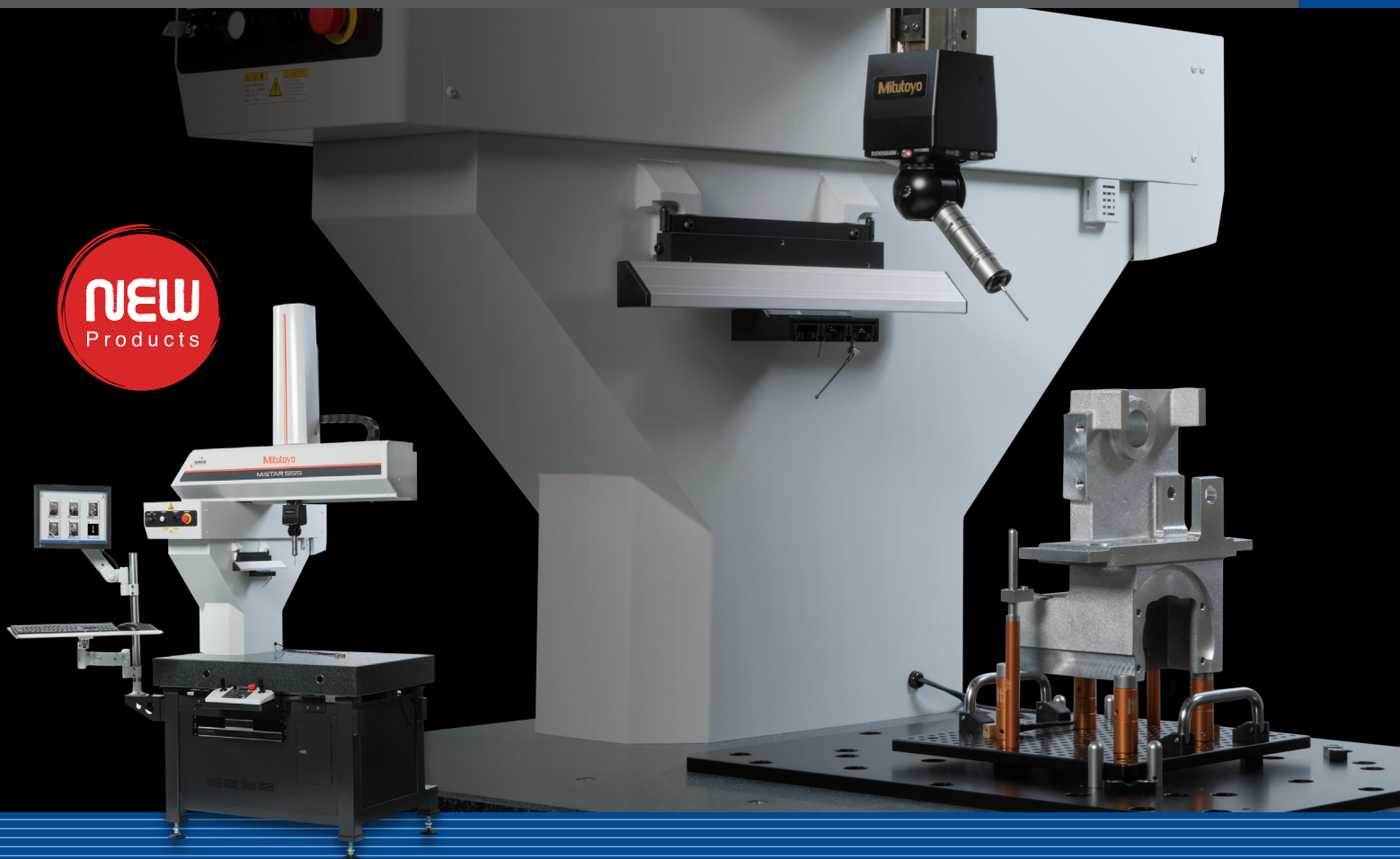

Bulletin No. 2321(3)

Next-generation Coordinate Measuring Machine for Shop Floor

MiSTAR Series

Highly Environment-resistant Coordinate Measuring Machine,
Allowing near-line or in-line inspection.

The MiSTAR Series is a CNC coordinate measuring machine conceived to be a "measuring machine for any environment." Wide accuracy-guaranteed temperature range, environment-resistant ABSOLUTE scale, and all-in-one space-saving design. With performance that sets it apart from conventional coordinate measuring machines, the MiSTAR Series will boost your productivity.



A brand new CMM design that provides cutting-edge capability in an extensive series of models that covers practically any measurement application in the small - to large size parts range.

The aesthetic design features bold colors that enhances a precision measuring instrument of the IoT age. Offering a choice of models for measuring from small-to-large-sized workpieces , the CRYSTA-Apex V Series delivers advances in accuracy, speed and versatility in this class of CMM.



MiSTAR 555

Measuring range

X: 500 mm

Y: 500 mm

Z: 500 mm

MiSTAR 575

Measuring range

X: 500 mm

Y: 700 mm

Z: 500 mm

Environment

A large industrial coordinate measuring machine (CMM) is shown in a dark environment. The machine is white and grey with a prominent red stripe. The word "Mitutoyo" is printed in red on the top surface, and "MiSTAR 555" is printed in white below it. A control panel with a red emergency stop button is visible on the left. A probe is mounted on the machine's arm, and a metal part is being measured on the table. The background is dark, highlighting the machine's structure.

Making measurements in harsh shop floor environments possible.

With an environment-resistant ABSOLUTE scale^{*1} and revamped body structure, the MiSTAR Series is a contamination-resistant coordinate measuring machine. Highly reliable as a result of real-time temperature compensation technology that guarantees accuracy over a wide temperature range, it delivers a length measurement error of just E_0, MPE of $2.2 + 3L/1000 \mu m^{*2}$. The MiSTAR Series can be installed and operated next to machine tools on production lines.

*1 ABSOLUTE-type, linear scale that provides an absolute value for each measurement point. Allows for reading of the position value straight after power on, without any setup.

*2 When used with SP25M in temperature environment 1 (18 °C to 22 °C).

Wide accuracy-guaranteed temperature range

The accuracy-guaranteed temperature range of 10 °C to 40 °C is achieved as a result of body architecture designed with temperature traceability in mind. The real-time workpiece temperature compensation makes temperature stabilization unnecessary, allowing for installation in a wider range of temperatures than conventional coordinate measuring machines.

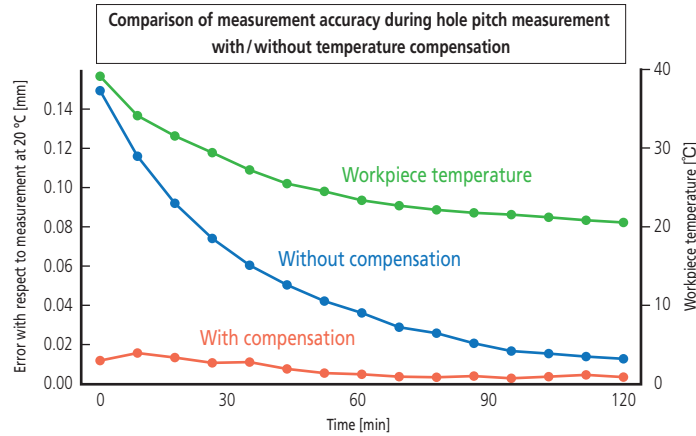

A coordinate measuring machine resistant to contamination

A newly developed environment-resistant ABSOLUTE scale having more than twice (in-house comparison), the contamination resistance of conventional models has been adopted, together with linear guides on the moving elements. The use of linear guides in place of air bearings eliminates the need for compressed air and eliminates contamination failure from the air source or the environment. This CMM can go without maintenance for long periods, even when used on a shop floor subject to airborne oil mist.

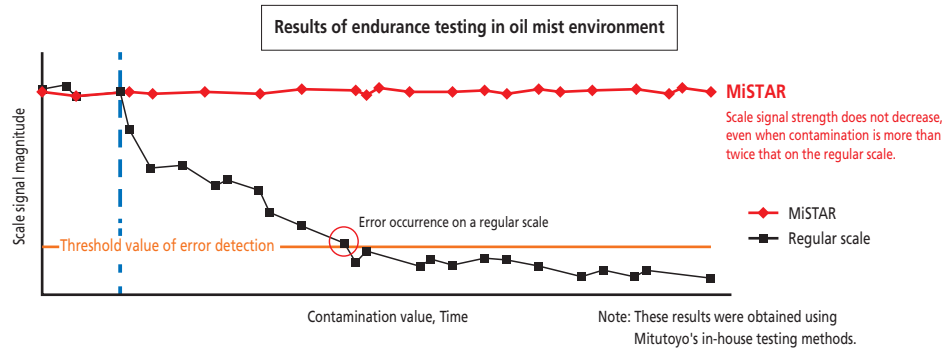

Energy-saving

With a wide accuracy-guaranteed temperature range and without the need for compressed air, the MiSTAR Series does not require a measuring room for its installation. This allows for substantial reduction in running costs compared with conventional coordinate measuring machines because it does not require a temperature controlled environment and air supply facilities.

Note 1: Air-conditioning power consumption is the average of models for domestic use and rooms up to 18 m².
 Note 2: Air-compressor power consumption is the average of models with a discharge rate of 42 L/min.

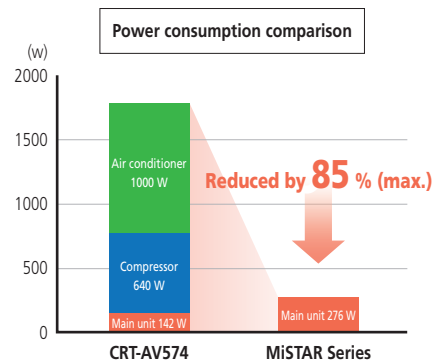



Usability

User-friendly design that reduces the operator's workload.

Cantilever architecture used to open the measurement area on three sides is the result of redesigning the measuring machine body design, starting from its material quality. Compared with a bridge or gantry design, it makes moving workpieces on and off the measuring table significantly easier. The user-friendliness of the MiSTAR Series, enabled by being open on three sides, can be seen especially on shop floors and the like where workspace is often limited.

Improved efficiency with three-sided open architecture

Three-sided open architecture while securing an ample measuring range of 570 (X) × 500 (Y) × 500 (Z) mm is very effective for moving workpieces on and off the measuring table.

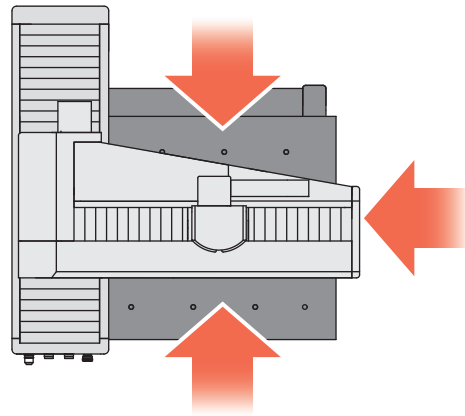

Simple, single button operation to start measuring

The MISTAR Series comes with the Quick Launcher, which enables simple and intuitive operation for easy part program execution. The touch panel monitor further improves operability, allowing anyone to easily execute part programs.



Positioning cannot be easier: Simply place the workpiece on the measuring table

The optional clamping system and pallet receiver with positioning mechanism allow you to start measuring just by placing the workpiece on the measuring table, relieving you of the trouble of positioning the workpiece.

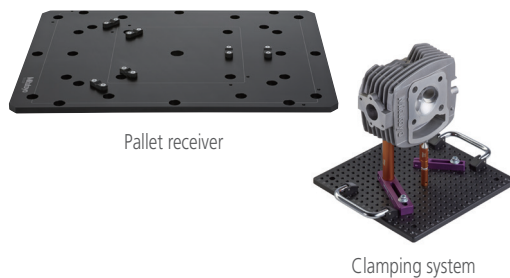

Smart Factory

From status management to preventive maintenance.

Kickstart your smart factory through visualization.

Allows you to monitor the operational status and condition of your coordinate measuring machine in real time, thereby realizing a non-stop system.



Status Monitor

Monitoring and logging of measuring machine operational status

Allows you to centrally monitor the operational status of coordinate measuring machines connected to a network, along with other measuring machines on the network. "Visualizing the operational status" allows you to reduce waste and improve the operating ratio of your production facilities.

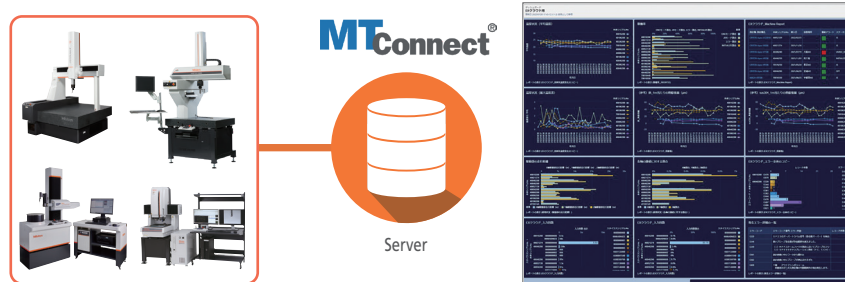

Condition Monitor

Preventive maintenance based on measuring machine status monitoring

"Visualization of status" through constant collection and accumulation of coordinate measuring machine status information, such as the probe touch count and total distance traversed by each moving element along each axis, helps to prevent sudden machine stoppages that could have been avoided by timely maintenance. Status monitoring enables you to achieve a non-stop production facility.

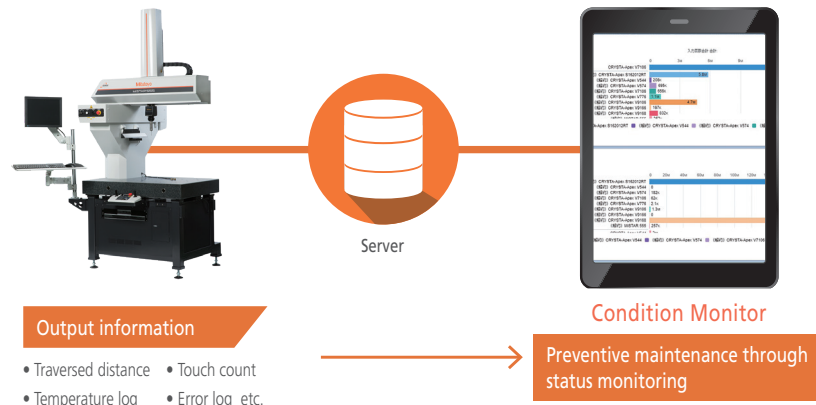

Note: Please contact the nearest Mitutoyo sales office for adaptable countries and regions.

MeasurLink®

Process management based on measurement data collection and analysis

"Visualization of quality" by collecting and accumulating measurement data from networked measuring machines, and then statistically processing this data on a server in real time helps to reduce defective products.

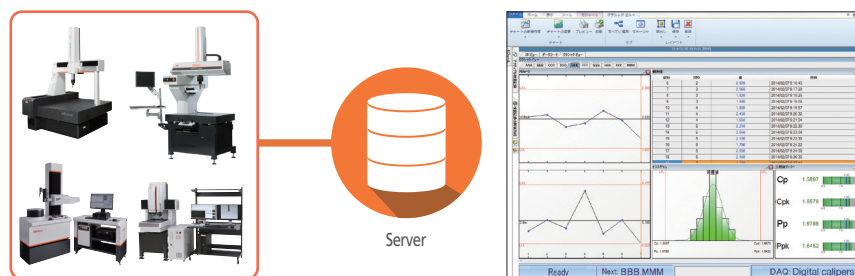

Compact

Footprint-reducing all-in-one architecture broadens the MiSTAR Series options for installation sites.

Coordinate measuring machine footprint comparison

CRYSTA Apex V544

Measuring range
X: 500, Y: 400, Z: 400
Footprint: 1.58 m²

MiSTAR 555

Measuring range
X: 570*, Y: 500, Z: 500
Footprint: 1.26 m²

*Automatic stylus changer attached: 500

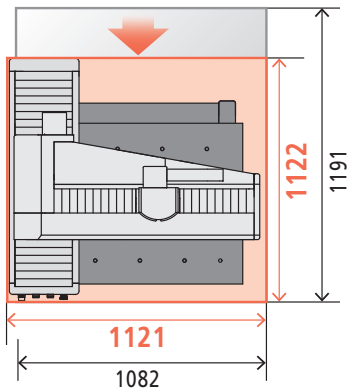

CRYSTA Apex V574

Measuring range
X: 500, Y: 700, Z: 400
Footprint: 1.68 m²

MiSTAR 575

Measuring range
X: 570*, Y: 700, Z: 500
Footprint: 1.49 m²

*Automatic stylus changer attached: 500

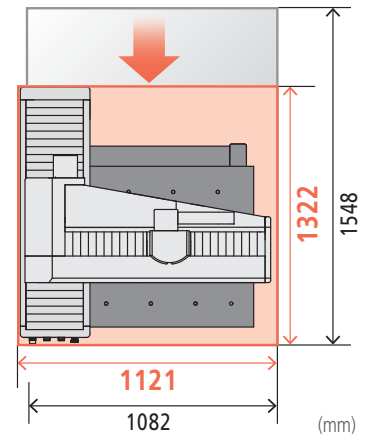

The storage cabinet for PC, machine controllers, etc., under the measuring table reduces the footprint by about 20 % when compared with that of other coordinate measuring machines with similar measuring range.

Option

Particularly effective to evaluate rotationally symmetrical parts like gears

Rotary table

This rotary table allows highly-accurate and efficient measurements of workpieces like rotationally symmetrical parts (gears, impellers and screw rotors). When used with a scanning probe, synchronized scanning measurements can be performed, enabling 4-axis scanning measurements.



Software

Application software that offers both functionality and operability.

We offer an extensive lineup of application software for generating measurement programs automatically, CAD nominal/actual comparisons, user designed report templates, gear analysis, airfoil analysis, EDM inspection, and so on. From simple to complex measurements, these software applications can resolve any measurement issues that our customers may encounter.

MCOSMOS

Data Processing Software for CMMs

A family of dedicated programs for coordinate measuring machines. A basic software with rich functionality and a wide variety of optional programs allows you to measure and analyze any workpiece.

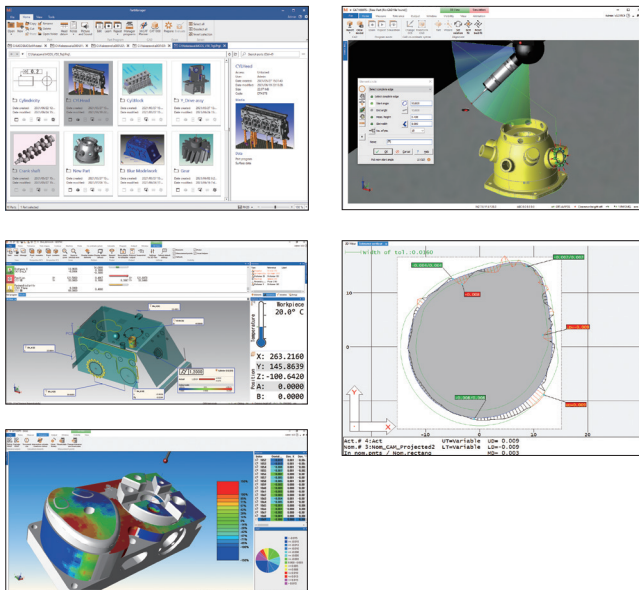

MiCAT Planner

Automatic Measurement Program Generation Software for CMMs

Allows you to automatically generate measuring programs from the 3D CAD model. Ready-to-use programs are generated in the shortest time based on the minimum number of probe repositionings, number of probe changes, and shortest measurement path assessed by the optimization software.

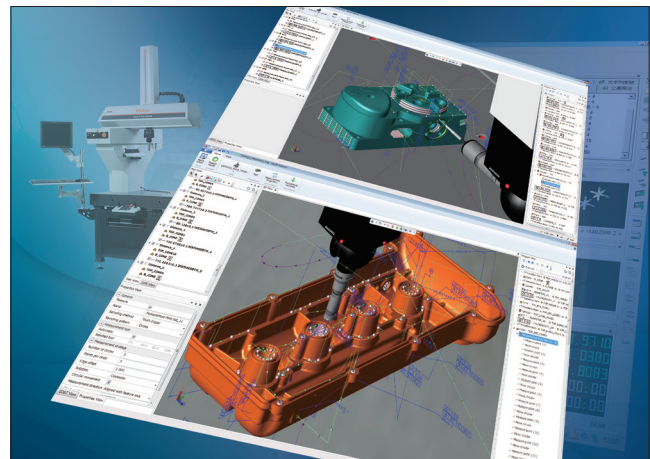

Coordinate Measuring Machines

Vision Measuring Systems

Form Measurement

Optical Measuring

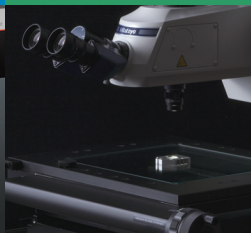
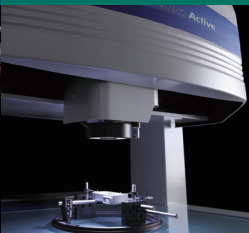

Sensor Systems

Test Equipment and Seismometers

Digital Scale and DRO Systems

Small Tool Instruments and Data Management



Whatever your challenges are, Mitutoyo supports you from start to finish.

Mitutoyo is not only a manufacturer of top quality measuring products but one that also offers qualified support for the lifetime of the equipment, backed by comprehensive services that ensure your staff can make the very best use of the investment.

Apart from the basics of calibration and repair, Mitutoyo offers product and metrology training, as well as IT support for the sophisticated software used in modern measuring technology. We can also design, build, test and deliver measuring solutions and even, if deemed cost-effective, take your critical measurement challenges in-house on a sub-contract basis.

My.Mitutoyo

Mitutoyo End User Portal

Search for products, request a product quote, take online metrology courses, and much more.

My.Mitutoyo.com puts everything Mitutoyo directly in front of you.



Find additional product literature and our product catalog

www.mitutoyo.com

Note: All information regarding our products, and in particular the illustrations, drawings, dimensional and performance data contained in this printed matter as well as other technical data are to be regarded as approximate average values. We therefore reserve the right to make changes to the corresponding designs. The stated standards, similar technical regulations, descriptions and illustrations of the products were valid at the time of printing. In addition, the latest applicable version of our General Trading Conditions will apply. Only quotations submitted by ourselves may be regarded as definitive. Specifications are subject to change without notice.

Mitutoyo products are subject to US Export Administration Regulations (EAR). Re-export or relocation of our products may require prior approval by an appropriate governing authority.

Trademarks and Registrations

Designations used by companies to distinguish their products are often claimed as trademarks. In all instances where Mitutoyo America Corporation is aware of a claim, the product names appear in initial capital or all capital letters. The appropriate companies should be contacted for more complete trademark and registration information.

Mitutoyo

Mitutoyo America Corporation

www.mitutoyo.com

One Number to Serve You Better

1-888-MITUTOYO (1-888-648-8869)

M³ Solution Centers:

Aurora, Illinois (Headquarters)

Boston, Massachusetts

Charlotte, North Carolina

Cincinnati, Ohio

Detroit, Michigan

Los Angeles, California

Seattle, Washington

Houston, Texas